

Engine V2203-M
Engine power 35,6 kW - 48,4 HP
Operating Weight 3.800 kg

E 245 K

Concrete solutions. Always



TECHNICALS SPECIFICATIONS

E 245 K

Operating weight with ballast	kg	3.800
Operating weight with backhoe	kg	3.800
ENGINE		
Type	KUBOTA V2203-M EU STAGE IIIA	
Max Power (2.600 rpm)	kW - HP	35,6 - 48,4
Max torque (1.700 rpm)	Nm	95
Displacement	cc	2.197
Number of cylinders	n°	4 in line
Cooling	water	
Consumption	lt/h	7,9
Alternator	V (A)	12 (45)
Battery	V (Ah)	12 (80/550)
HYDRAULIC SYSTEM		
Pump type	Nr. 1 gear pump for hydraulic utilization	
Pump capacity	lt/min	46,5
Max. circuit calibration pressure	bar	180
High Flow System (optional): Max capacity Max pressure	lt bar	90 180
TRANSMISSION		
Type	hydrostatic with variable pump and motor, coupled to a dinaflow at two ratio by electrohydraulic command	
Travelling speed	mph	1 ^a : 0 ÷ 10 / 2 ^a : 0 ÷ 23,5
Dimensions tires	12x16.5	
BRAKES		
Service brakes	Incorporated axles multiple disk in oil bath	
Parking brakes	Mechanical, acting in the transmission with manual control	
PERFORMANCES		
Operating load (front bucket)	kg	1.600
Teeth breakout force (front bucket)	daN	3.600
Teeth breakout force (backhoe bucket)	daN	2.750
Standard bucket capacity	m ³	0,45
Standard bucket width	mm	1.450
Max slope	60% - 30°	
FILLINGS		
Fuel tank	lt	50
Hydraulic oil tank	lt	47
Hydraulic circuit capacity	lt	62
Cooling system capacity	lt	10
Engine oil	lt	7,2

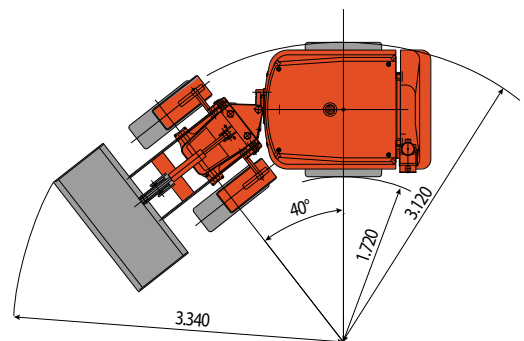
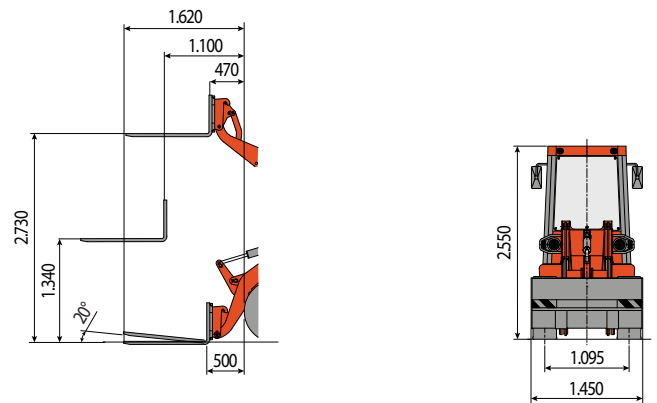
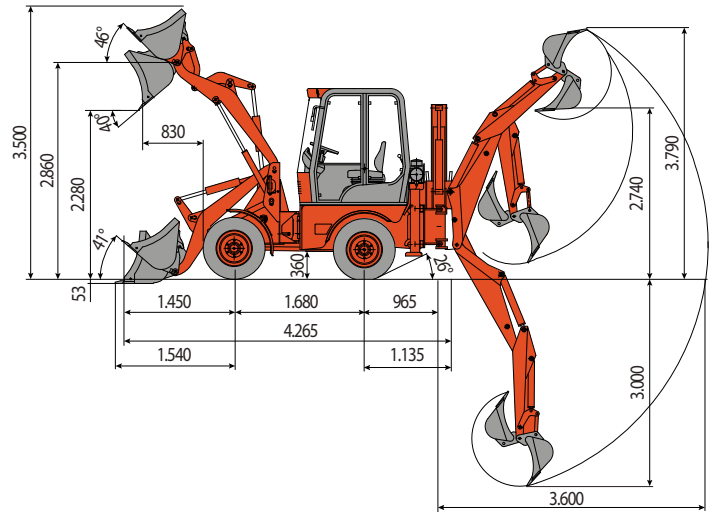

- Homologation for road traffic (only Italy).
- ROPS ISO 3471 and FOPS 1st level ISO 3449 homologated cabin.
- Front and back working lights for night road circulation.



EUROCOMACH®

Sampierana S.p.A.

47021 S.Piero in Bagno (FC)
via Leonardo da Vinci, 40
Tel +39 0543.904211
Fax +39 0543.918520
www.eurocomach.com